



THE FANS OF INDIA

CENTRIFUGAL FANS FOR
INDUSTRIAL & COMMERCIAL
APPLICATIONS



www.ventechsystems.com

SALIENT FEATURES

VENTECH Centrifugal Blowers are well engineered, high efficiency air moving blowers, incorporating all the latest improvements to suit any type of industrial application like Fume or Vapour exhaust, Dust Handling, Material Conveying, Induced Draft, Forced Draft and so forth in foundries, Power Plants, Engineering Industries, Cement and Chemical producing plants and the like. The Blowers are designed to meet each customer's individual specifications.

⊗ **TYPES :** VENTECH offers wide range of Centrifugal Fans with highly efficient impellers of various types : Backward Inclined, Backward Curved, Backward Flat Sloping, Forward Curved and Straight Radial, depending upon application and customer's specifications.

⊗ **CONFIGURATION :** SWSI (Single Width Single Inlet) DWDI (Double Width Double Inlet)

Provided with single and multiple (parallel or series operation) impellers to suit wide range of air discharge and pressure development combinations.

⊗ **SIZE & PERFORMANCE RANGE :**

- Size : Impeller diameters upto 2050 mm
- Airflow : Single Width (SWSI) upto 1,25,000CMH & Double width (DWDI) up to 2,75,000 CMH
- Pressure : Single Stage: upto 1200 mm.wg.
Two-stage: upto 2500 mm.wg.
- Temperature : Upto 425°C







CONSTRUCTION FEATURES

HOUSING CONSTRUCTION

- Centrifugal Fans are made of mild steel (IS 1079/2062) rigid casing with Inspection window and drain plug. The blowers have a circular air inlet and a rectangular cross section air outlet port.
- Continuously welded fan housings provide strength and durability for longevity.
- The use of conical shrouds make fans less susceptible to performance losses attributed to poor inlet conditions.
- All housing outlets have flanged connection for easy connection to ducting.

IMPELLERS

- The impeller wheels are of multi-blade construction with blades of special contour, engineered to handle varied quality air streams.
- All impeller wheels are precision balanced as per provisions of international standard ISO: 1940 for smooth operation.
- Available Centrifugal Fan Designs:

Parameters				
Wheel Type	Double Curved Backward tip discharge limit load design ('LL' type)	Backward Curved ('B' type)	Backward curved with Radial Tip Discharge with Self Cleaning properties('R')type & Backward Flat Sloping ('P')type	Straight Radial Blade Semi-open type impeller with a heavy back plate without any shroud('S') type
Fan Series	VSLL –S (Single Inlet) VSLL – D (Double Inlet)	VSBL,VMBM, VHBM, VHBH, VSBB & VSMB	VMRL,VMRM,VHRM, VSLP, VSMP & VSHP	VSSL, VMSL, VMSM, VHSM & VHSH
Range of Efficiency	80-85%	75-82%	72-80%	65-72%
Application	Air Conditioning, Ventilation & Air Cooling	General Ventilation, DC Motor Ventilation, Drying Application, Dust Proofing, Pneumatic conveying	Food processing, Boilers, Foundries, Welding shops, Pharma , Chemicals, etc.	Pneumatic Conveying Food processing, Abrasive & Sticky environments, Dust and Fume Extraction
Type of Dust Loading	Clean Air	Light dust loads	Moderate dust Heavy dust loading	Heavy dust Loads (Dry and Fibrous)

BEARING

All standard service blowers except for direct driven blowers are supplied with grease lubricated Heavy Duty Double Row Ball / Spherical roller bearings ensuring smooth operation. Bearings for Blowers with cooling disc are filled with special grease grade suitable for high temperatures.



OPTIONAL CONSTRUCTION

SPECIAL MANUFACTURING :

These industrial blowers can be manufactured in stainless steel, carbon steel and aluminium, when required to handle corrosive fumes / abrasive dust. FRP lining and metal spray finishes can also be offered on request.

SPARK RESISTANT CONSTRUCTION

Fan applications may involve the handling of potentially explosive or flammable particles, fumes or vapours. Such applications require careful consideration by the system designer to ensure safe handling of such gases. It is the specifier or the user's responsibility to specify the type of spark resistant construction with full recognition of the potential hazards and the degree of protection required.

SWING OUT CONSTRUCTION

Swing-out fans are ideal for applications requiring frequent cleaning and inspection of the fan wheel and interior of the housing such as found in spray painting booth exhaust.



SPLIT HOUSINGS

All fans are designed to permit impeller removal through the fan inlet. To suit installation as well as transportation requirements, Ventech Systems Pvt. Ltd. offers horizontal split, pie-shaped split housings allow fan impeller and shaft removal without disconnecting ductwork.



HIGH TEMPERATURE MODIFICATIONS Construction

Standard fan design options are available to handle airstream temperatures to 425°C. Consult for applications over 425°C. The fan bearings should be kept outside of the hot airstream and below 55°C ambient. High temperature operating limits, available arrangements, and necessary modifications are shown in Table 1.



Shaft Cooler and Shaft Seal

Table 1. High Temperature Construction Requirements

TEMPERATURE (°F)	TYPE OF BEARING	LUBRICATION	OTHER REQUIREMENTS	AVAILABLE ARRANGEMENTS
-30°C to +150°C	Ball or Roller	Grease	Standard Fan	Arr. 1, 8, 9, 9F, 10 Arr. 3 and 3F to 130°F Arr. 4 to 180°F
150°C to 260°C	Ball or Roller	High Temp. Grease	Shaft Cooler, Shaft Seal. For Arr. 9 & 10 Fans, a Motor Heat Shield is Included.	Arr. 1, 8, 9, 9F, 10
260°C to 425°C	Ball or Roller	High Temp. Grease	High Temp. Aluminum Paint Shaft Cooler, Shaft Seal. For Arr. 9 & 10 Fans, a Motor Heat Shield is Included.	Arr. 1, 8, 9, 9F, 10 (Arr. 9 & 10 Limited to 600°F)

DRIVE ARRANGEMENTS



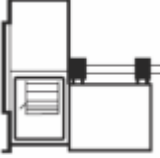
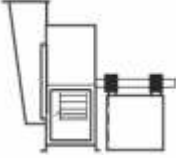
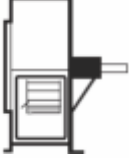
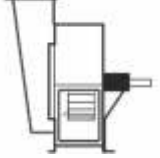
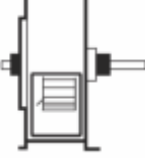
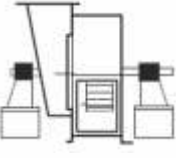
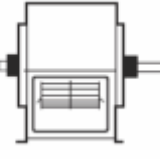
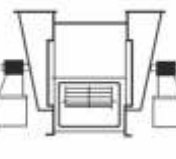
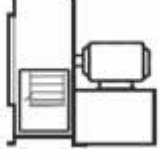
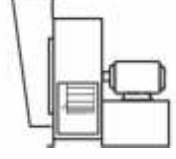
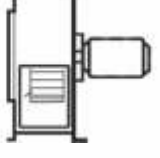
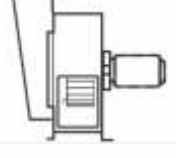

Centrifugal Fans as per AMCA Standard 99-2404-03

AMCA Drive Arrangement	ISO 13349 Drive Arrangement	Description	Fan Configuration	Alternative Fan Configuration
1 SWSI	1 or 12 (Arr. 1 with sub-base)	For belt or direct drive. Impeller overhung on shaft two bearings mounted on pedestal base. Alternative: Bearing mounted on independent pedestals with or without inlet box.		
2 SWSI	2	For belt or direct drive. Impeller overhung on shaft, bearings mounted in bracket supported by the fan casing. Alternative: With inlet box		
3 SWSI	3 or 11 (Arr. 3 with sub-base)	For belt or direct drive. Impeller mounted on shaft between bearings supported by the fan casing. Alternative: Bearing mounted on independent pedestals with or without inlet box.		
3 DWDI	6 or 18 (Arr. 6 with sub-base)	For belt or direct drive. Impeller mounted on shaft between bearings supported by the fan casing. Alternative: Bearing mounted on independent pedestals with or without inlet box.		
4 SWSI	4	For direct drive. Impeller overhung on motor shaft. No bearings on fan Motor mounted on base. Alternative: With inlet box		
5 SWSI	5	For direct drive. Impeller overhung on motor shaft. No bearing on fan Motor flange mounted to casing Alternative: With inlet box		

NOTES: SW - Single Width, DW - Double Width, SI - Single Inlet, DI - Double Inlet

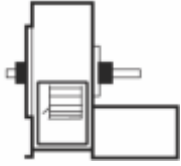
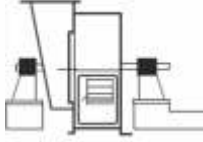
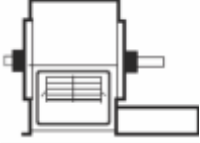
DRIVE ARRANGEMENTS

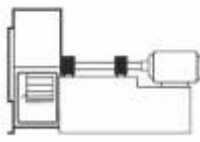
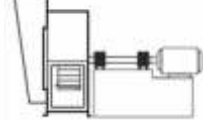
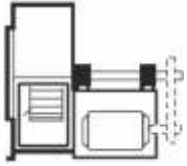

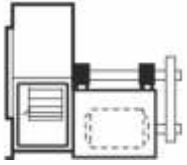
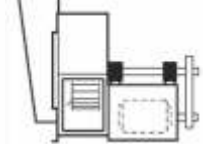













Centrifugal Fans as per AMCA Standard 99-2404-03

AMCA Drive Arrangement	ISO 13349 Drive Arrangement	Description	Fan Configuration	Alternative Fan Configuration
7 SWSI	7	<p>For coupling drive.</p> <p>Generally the same as Arr. 3 with base for the prime mover.</p> <p>Alternative: Bearing mounted on independent pedestals with or without inlet box</p>		
7 DWDI	17 (Arr. 6 with base for motor)	<p>For coupling drive.</p> <p>Generally the same as Arr. 3 with base for the prime mover.</p> <p>Alternative: Bearing mounted on independent pedestals with or without inlet box.</p>		
8 SWSI	8	<p>For direct drive.</p> <p>Generally the same as Arr. 1 with base for the prime mover.</p> <p>Alternative: Bearings mounted on independent pedestals with or without inlet box.</p>		
9 SWSI	9	<p>For belt drive.</p> <p>Impeller overhung on shaft two bearings mounted on pedestal base.</p> <p>Motor mounted on the outside of the bearings base.</p> <p>Alternative: With inlet box.</p>		
10 SWSI	10	<p>For belt drive.</p> <p>Generally the same as Arr. 9 with motor mounted inside of the bearings pedestal.</p> <p>Alternative: With inlet box.</p>		

NOTES: SW - Single Width, DW - Double Width, SI - Single Inlet, DI - Double Inlet

STANDARD CONFIGURATIONS

Designations for Rotation & Discharge Of Centrifugal Fans as per AMCA Standard 99-2406-03.

 Clockwise Up Blast CW 360	 Clockwise Top Angular Up CW 45	 Clockwise Top Horizontal CW 90	 Clockwise Top Angular down CW 135	 Clockwise Down Blast CW 180	 Clockwise Bottom Angular Down CW 225	 Clockwise Bottom Horizontal CW 270	 Clockwise Bottom Angular Up CW 315
 Counterclockwise Up blast CCW 360	 Counterclockwise Top Angular Up CCW 45	 Counterclockwise Top Horizontal CCW 90	 Counterclockwise Top Angular down CCW 135	 Counterclockwise Down Blast CCW 180	 Counterclockwise Bottom Angular Down CCW 225	 Counterclockwise Bottom Horizontal CCW 270	 Counterclockwise Bottom Angular Up CCW 315

- ⊗ Direction of rotation is determined from drive side of fan.
- ⊗ On single inlet fans, drive side is always considered as the side opposite fan inlet (even when driven through fan inlet).
- ⊗ On double inlet fans with drives on both sides, drive side is that with the higher powered drive unit.
- ⊗ Direction of discharge is determined in accordance with diagrams. Angle of discharge is referred to the vertical axis of fan and designated in degrees from such standard reference axis. Angle of discharge may be any intermediate angle as required.
- ⊗ For fan inverted for ceiling suspension, or side wall mounting, direction of rotation and discharge is determined when fan is resting on floor.

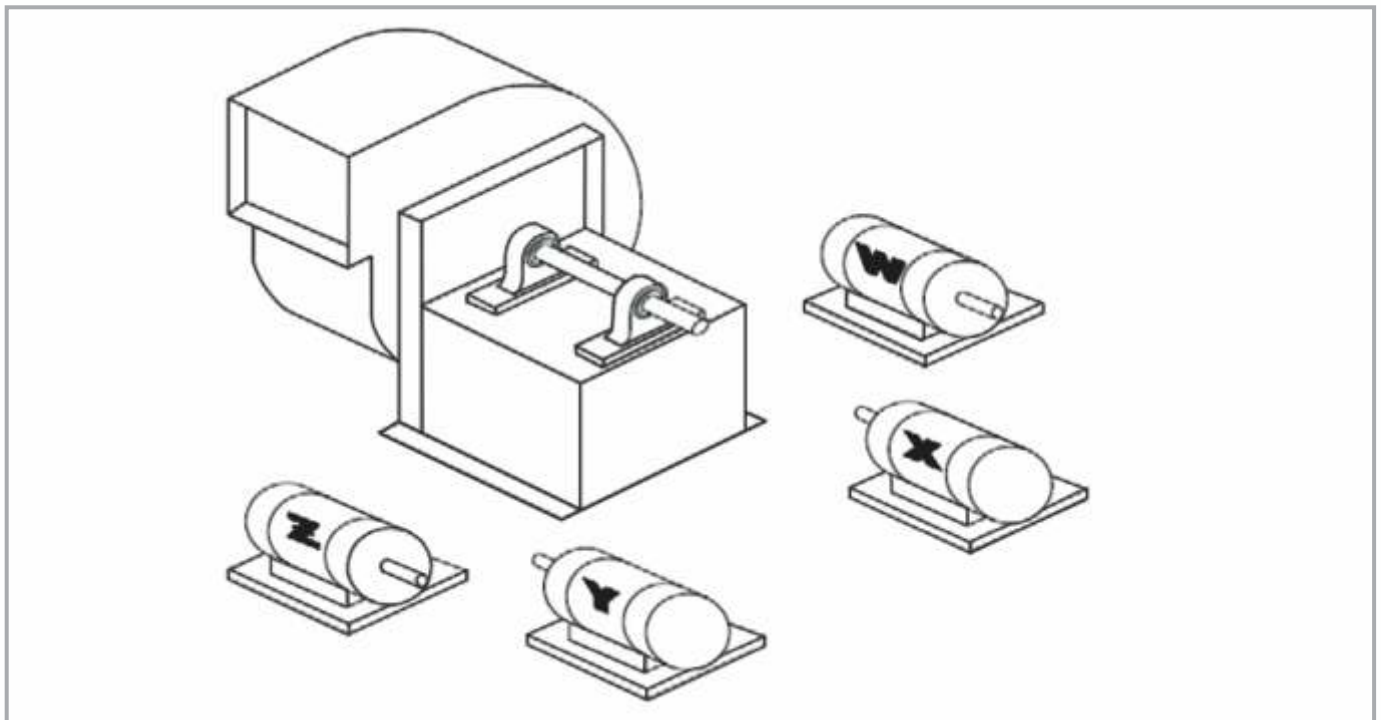

Motor Position

The position of the motor for belt drive centrifugal fan is in accordance with AMCA standard 99-2407-03. Location of motor is determined by facing the drive side of fan and designating the positions by letters W, X, Y or Z.

OPTIONAL FAN ACCESSORIES

- ⊗ **OUTLET DAMPER** - (Opposed bladed or parallel bladed type) is best suited for control over range of air volume and is highly efficient in performance. These dampers can be operated manually or by actuator or by pneumatic regulators.
- ⊗ **INLET DAMPERS** - Heavy Duty MS fabricated butterfly type round inlet dampers can be provided at the fan inlet for regulating air flow.
- ⊗ **VARIABLE INLET VANE DAMPER** - Designed for accurate control of air volume. The damper will spin the air in the direction of wheel rotation resulting in a maximum saving in power at the reduced ratings desired. The operating mechanism is outside the inlet ring, completely out of the air stream.
- ⊗ **COMMON BASE FRAME** - is a structural steel base with channels which provides common support to fan motor and drive including guards. The base is designed for use with or without vibration isolators.
- ⊗ **ACCESS DOOR** - are bolted and gasketed for easy opening for wheel inspection or maintenance. Doors are provided at 3 o'clock or 9 o'clock positions on housing scroll opposite fan discharge.
- ⊗ **HEAT SLINGER / SHAFT COOLER AND SHAFT SEAL** - Cast aluminium or steel fabricated shaft cooler is used to dissipate the heat and protect the fan bearing for all application over 100° C. A shaft seal reduces leakage and protects the bearings from contaminated air stream.
- ⊗ **HOUSING DRAIN** - Threaded pipe coupling welded to the lowest point in the housing scroll.
- ⊗ **INLET AND OUTLET SAFETY SCREENS** - Safety screens are available for mounting in the fan inlet or outlet in non-ducted applications.
- ⊗ **VIBRATION ISOLATOR** - Rubber – in – shear or spring type vibration isolators are available for all sizes and arrangement.
- ⊗ **BELT GUARD** - A belt guard protects personnel from the moving drive parts. Both standard and totally enclosed type guards are available.
- ⊗ **V-BELT DRIVE SET** - Belt drive offer an economical yet flexible means of transmitting power to the fans. Pulleys supplied are duly balanced.
- ⊗ **FILTERS** - Filters with their holding frame and adapter cone can be provided depending on the application.
- ⊗ **INLET & OUTLET FLEXIBLE CONNECTIONS** - Flexible Connectors consisting of fabric, secured to galvanized sheet metal on either side by a double lock seam is inserted between the equipment / air duct and the ductwork to provide a wear resistant Air tight flexible connection to eliminate vibrations, noise and rattles.

PAINT & FINISH

Standard Fans are spray painted with synthetic enamel paint.

Following special finishes / coatings can also be provided depending on the application:-

- ⊗ Spark Proof Construction.
- ⊗ FRP Coating.
- ⊗ Epoxy Paint.
- ⊗ Coating of special corrosion resistant paints
- ⊗ Zinc Spray / Galvanizing
- ⊗ Chlorinated rubber paint.
- ⊗ For High temperature (from 100^o.C to 425 deg.C) application, Aluminium cooling disc is provided and the fan is painted with Heat Resistant Aluminium Paint.



TESTING AND INSPECTION

Centrifugal Fans can be tested in accordance with IS-4894 standards on customer's request.



AFTER - SALES SERVICES

Ventech can cater to the requirement of replacement parts for repairing, re - building or upgrading of Ventech or other fan manufacturers' equipments. We can replace wheels, shafts, bearings, damper & entire fan assemblies.

DIDW CENTRIFUGAL FANS

CENTRIFUGAL FANS FOR AIR WASHER UNITS AND AIR HANDLING UNITS

⊗ LIMIT LOAD CENTRIFUGAL FANS

These fans are provided with impellers having double curved backward discharge tip blades and stationary inlet guide vanes which reduces the turbulence at the fan entry apart from their serving as an effective guard. These fans are of limit load characteristics with aerodynamically designed impellers which allow handling large volumes of air over a wide range of pressure requirements at low operating costs. The horsepower is self-limiting and reaches a maximum limit at a given speed. This permits the selection of motors based on brake horsepower requirements without danger of getting overloaded at that speed.

We manufacture & supply a comprehensive range of these blowers to cater to the requirement of vast segment of industrial air handling requirement by means of supplying single width single inlet (SWSI) or double width double inlet (DWDI) Centrifugal Fans.

The impellers have deep wide blades which are robust and provide extra rigidity thus low noise level during operation as compared to other backward curved blowers with other designs.

We offer various types of class of construction depending on the pressure requirement and application.

⊗ FORWARD CURVED FAN

The Forward curved series of DWDI / SWSI centrifugal fans with forward curved impellers are suitable for supply or extract applications in commercial, process and industrial HVAC systems.

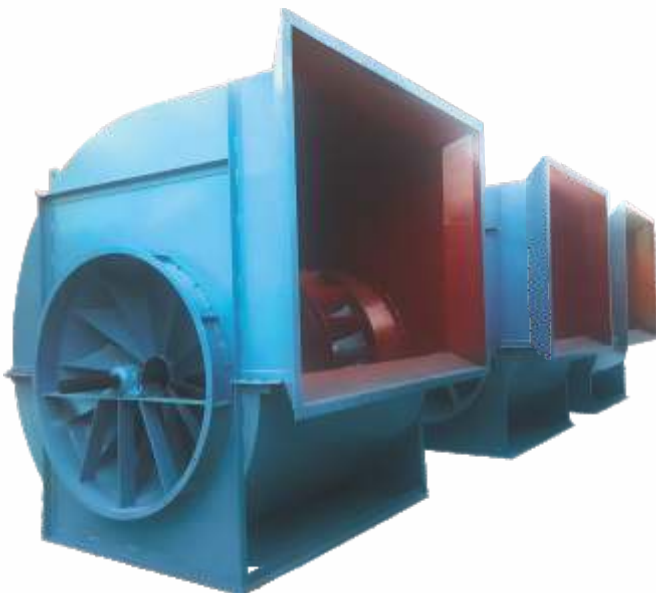

LIMIT LOAD BACKWARD CURVED BLOWER



FORWARD CURVED BLOWER

CABINET INLINE FANS

- ⊗ Series : VSCF (Cabinet Fans)
- ⊗ Wheel size : 9" – 12" (225 – 300 MM)
- ⊗ Capacity : 400 to 3200 CFM
- ⊗ Static Pressure : 5.0 – 50 mm
- ⊗ Drive Options : Direct Drive & Belt Drive
- ⊗ Wheel Constructions : Highly reliable Forward curve DWDI wheel with Galvanized steel construction, wheels built with a special lock forming process, holding the blades on Centre disc and end ring to get positive blade retention.
- ⊗ Cabinet : Single skin construction in 18 Gauge GI.
Access door is provided for easy serviceability.
- ⊗ Optional : Double skin construction in 18 Gauge GI construction. The panels are sandwiched with sound absorption material.



FAN LAWS

Performance of a fan can be predicted using fan laws for different operating conditions.

1. Volume Flow:

$$q_{v2} = q_{v1} \times (n_2/n_1)^1 \times (d_2/d_1)^3$$

2. Pressure:

$$p_2 = p_1 \times (n_2/n_1)^2 \times (d_2/d_1)^2 \times (\rho_2/\rho_1)^1$$

3. Absorbed Power:

$$P_{R2} = P_{R1} \times (n_2/n_1)^3 \times (d_2/d_1)^5 \times (\rho_2/\rho_1)^1$$

4. Density:

$$\rho_2 = \rho_1 \times (B_2/B_1) \times (T_1/T_2)$$

5. Efficiency %:

$$(q_v \times p_1 F) / 10 P_R$$

6. Total Pressure:

$$p_{TF} = p_v F + p_d F$$

7. Velocity Pressure:

$$p_d = 0.6 v^2 \text{ (Standard air)}$$

Nomenclature for symbols used in this page:-

q_v = volume flow of air, m³/sec

B = barometric pressure

n = rotational speed of fan

T = absolute temperature, K (K = °C + 273)

d = diameter of fan

$p_t F$ = fan total pressure, Pa

p = pressure developed by the fan

$p_s F$ = fan static pressure, Pa

ρ = density of air, kg/m³

$p_v F$ = fan dynamic/velocity pressure, Pa

P_R = power absorbed by the fan, kW

p_d = system dynamic/velocity pressure, Pa

v = velocity of air, m/sec

subscripts 1 & 2 indicate the original & changed operating conditions.

Air Movement and Control Association International, Inc.

Certifies that

Ventech Systems Pvt. Ltd.

*Having satisfied the membership requirements, has been granted membership in the
Air Movement and Control Association International, Inc.*

*Member Since
February, 2014*

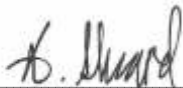

AMCA International President



Executive Director

RANGE OF PRODUCTS

● Axial Flow Fans ● Centrifugal Blowers ● Kitchen Scrubbers ● Ventilation Units
Air Cooling Units ● Dust Collectors ● Rotary Airlocks ● Air Handling System Accessories

RANGE OF SYSTEMS

- Pressurisation & Ventilation ● Evaporative Air Cooling ● Dust Extraction & Collection
- Fume Extraction & Collection ● Fresh Air Supply & Exhaust ● Kitchen Ventilation
- Pneumatic Conveying ● Air Conditioning



We handle AIR with care...

VENTECH SYSTEMS PVT. LTD.

(An ISO 9001 : 2015 Certified Company)
(A recipient of Bhartiya Udyog Ratna Award)
(Authorized Channel Partners of Hitachi & LG)



Corporate Office: 511, Vikas Deep, Laxmi Nagar District Centre, Vikas Marg, New Delhi – 110 092 (India)

Phone: + 91 – 11 – 22454054 , 22454059 **Mobile:** + 91 97110 03363

Telefax: + 91 – 11 – 42448063 • **E-mail:** info@ventechsystems.com, sales@ventechsystems.com

Branch Office: 410, Angel Mega Mall, CK-1, Kaushambi, Ghaziabad

Works: Ghaziabad & Delhi

Regional Representatives: Lucknow, Raipur, Ahmedabad, Hyderabad, Karnal

Overseas Representatives: Canada, Singapore, South Africa



All Rights reserved. No part of this publication may be copied or published by means of printing, photocopying, microfilm or otherwise without prior written consent of Ventech Systems Pvt. Ltd. This restriction also applies to the corresponding drawings and diagrams.

In view of our constant endeavour to improve the quality of our products & systems, we reserve the right to alter the specifications without prior notice. We reserve the right to modify the specifications in accordance with improved designs. Although every effort will be made to maintain accuracy in the data given, the figures must be taken as approximate and in no way binding. Contact us for more information.